

Varenummer: 2302151782
Beskrivelse: Stjernegreb
VTT.50-SST-M10 CLEAN

Mål

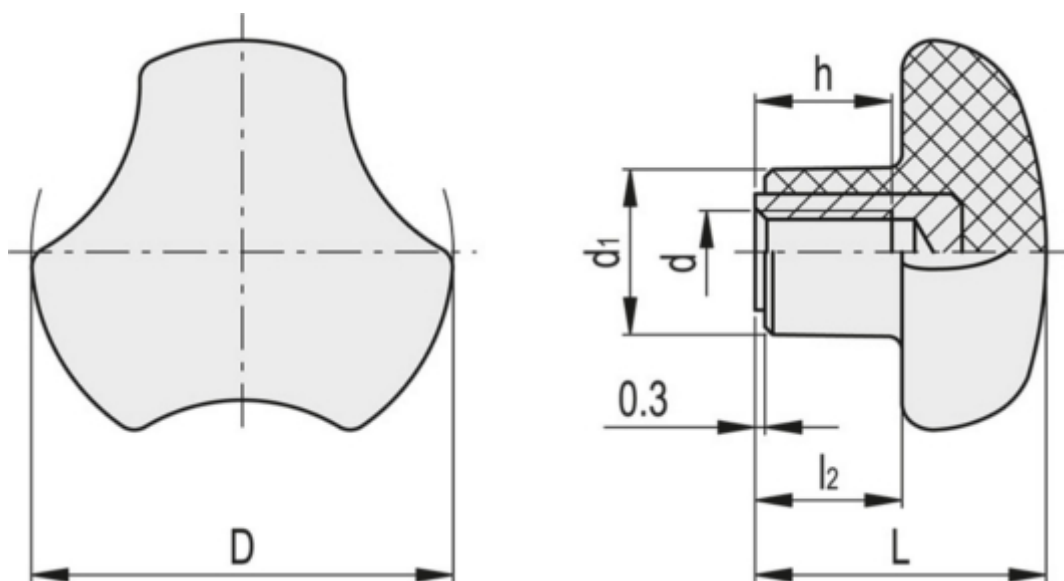

D	= 50
D1	= 19
DH	= M10
h	= 17
l2	= 15
L	= 30
Vægt i (g)	= 37